



### Characteristics

RHINO is a 2-cylinder hydraulic piston pump with S-valve and variable output for shotcrete, micro-concrete, special concrete. RHINO is a reliable choice in tight jobsites.

### Applications

- Shotcrete works

---

- Concrete, grouts, structural mortars, refractory mortars

---

- Self-levelling floor screeds

---

- Land reinforcement

---

- Micro-piles, pressurized injection of mortars and cementitious slurries

---

- Compaction grouting

---

### Dimensions

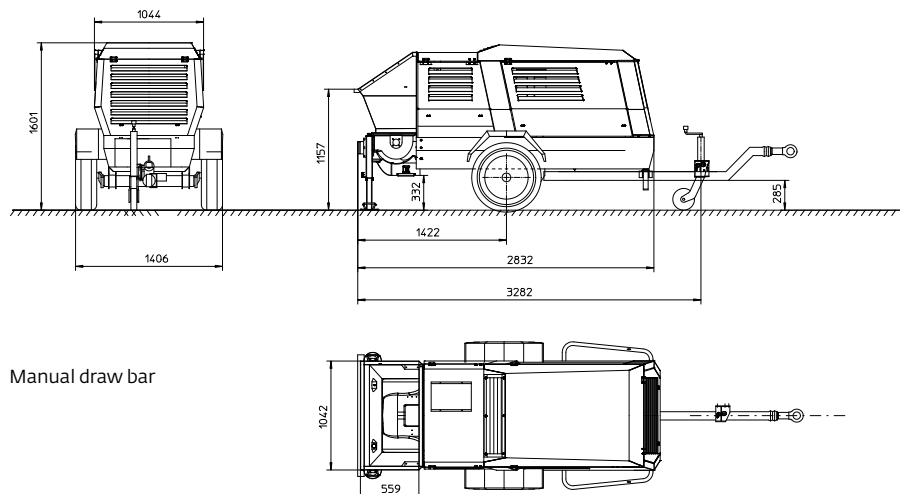



# RHINO

## Technical data

Liquid cooled diesel engine		Yanmar 4TNV88 - 4 cyl. 36,4 kW - 49,5 HP (Stage IIIA)
Electric motor (upon request)		22 kW - 400 V 50 Hz
Infinitely adjustable output*	m <sup>3</sup> /h	from 2 to 15
Max. aggregate size	mm	25
Max. working pressure	bar	80
Pumping cylinders	mm	Ø 120 stroke of 700 mm
Max. strokes		30
Drive cylinder diameter	mm	80/50
Delivery manifold	mm	Ø 100
Hopper capacity	l	250
Delivery distance*	m	200
Delivery height*	m	100
Filling height	cm	135
Chassis		Manual drawbar - fixed axle and pneumatic wheels
Dimensions (L x W x H)	cm	336 x 150 x 160
Weight (draw-bar)	kg	1.600

\* The data indicated are theoretical and depend on the quality and consistency of the materials to be used, wear and tear of the pump and the diameter of the hoses. The performance in distance and height can not be reached simultaneously.

## Technical advantages

Thanks to its unique mechanical engineering, to the dimensions of the pump-valve assembly and to the configuration of the hydraulic system, the machine can be used for transporting and casting concrete, for spraying mortars and for shotcrete.

With 80 bar of maximum pressure, the machine can pump concrete between 2 and 15 cubic meters per hour up to considerable heights and distances.

It can be equipped with steel pipes or rubber hoses of different diameters depending on the amount and the particle size of the aggregates to be pumped.

## Scope of delivery

- 4-cylinder liquid cooled diesel engine
- Hopper assembly with S-valve and agitator
- Centralized lubrication system
- Hydraulic circuit with optimized exchange sequence
- Electromechanical control board
- Variable displacement pump
- 30 m cable remote control
- Accessory box
- Grill with 15 mm mesh with electric vibrator
- Additive-dosing peristaltic pump

## Options

Shotcrete gun kit Ø 40mm with 2" concrete hose, length 8m with 1" air and additive lines, length 10m