

## Cifa Shotcrete Telescopic CST 8.20

### MOBILE CONCRETE SPRAYER

Shotcrete Boom	CST
Pumping Unit	PAS 206
Driven mode	Diesel
Shotcreting	Electric
Chassis	2 axles 4WD



#### Dimensions and Performances

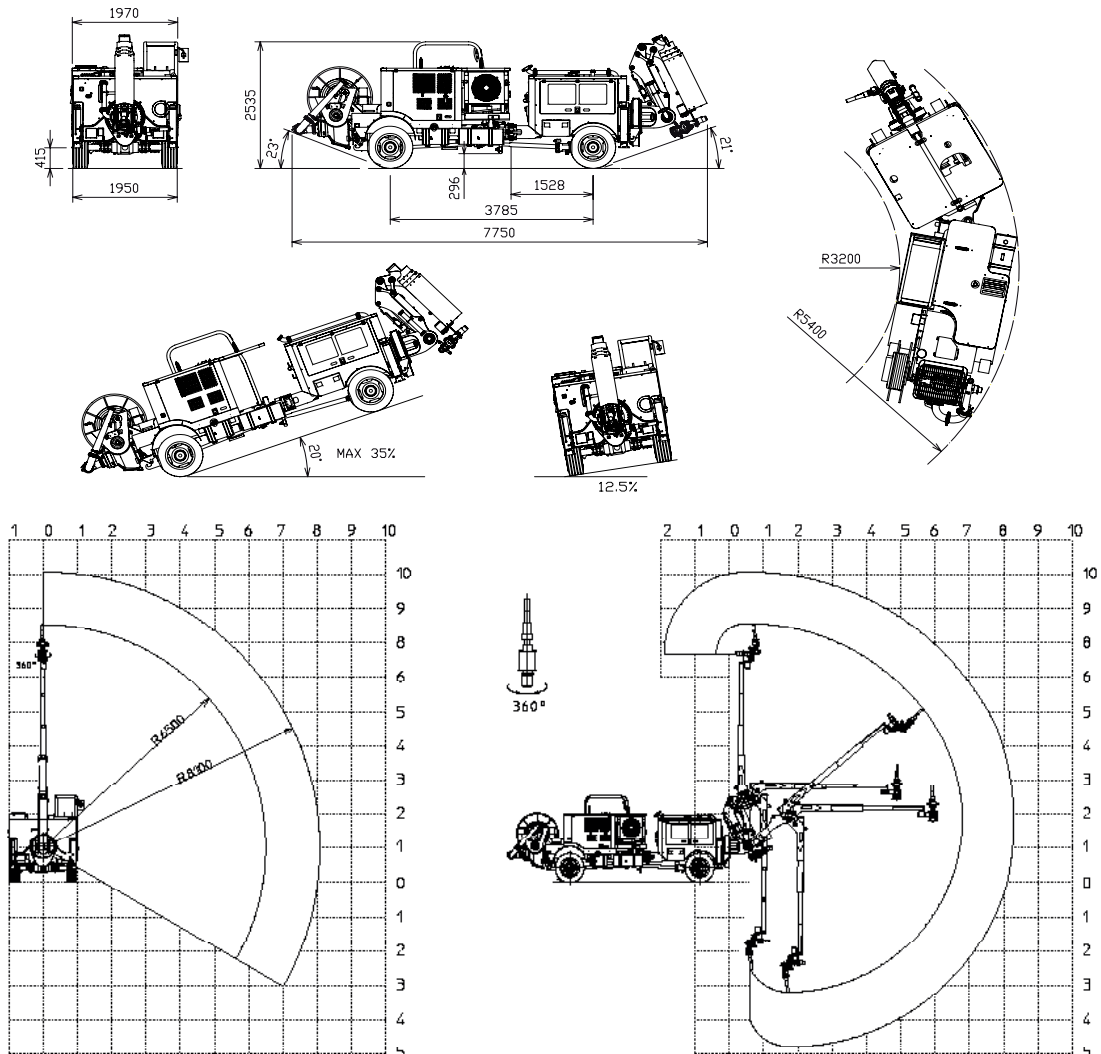

# Cifa Shotcrete Telescopic CST 8.20

## Main Features

- Diesel engine
  - D914L05 STEP III-A, 72 kW, air cooled
  - TD3.6 L04 STEP III-B, 55 kW, liquid cooled catalytic silencer
  - fuel tank 60 l
- Driving cab
  - FOPS + ROPS certification
  - reversible driving position
- Carrier chassis
  - articulated frame
  - 4 wheel drive
  - axles planetary type ,Dana Spicer
  - 1 speed
  - max. 20 km/h
- Uniflux H1.0 dosing system
  - peristaltic pump with hydraulic drive
  - electronic management
- Concrete pump
  - Electric operated
  - proportional flow regulation
  - electric vibrator fitted to the grid
- Proportional radio-remote control
  - n°1 transmitter
  - safety cable
- Washing system:
  - high pressure water pump, 16 l/min – 120 bars
  - hydraulic drive
  - nozzle and 10 m of pipe
  - water tank , 90 l
  - handpump for concrete anti-adhesion protection
- Automatic lubrication in 6 points for:
  - S valve
  - pumping group mixer
- Electrical system
  - Carrier:
    - 24 V
    - battery 2 x 120 Ah
    - alternator 55 A
    - front lights 2 x 55 W
    - rear lights 2 x 55 W
  - Shotcreting operations:
    - .electric motor ABB 45kW IE3
    - .working lights N°4 x 45W-4800 lumen xenon
    - working lights on hopper N°1 x 70W
- One colour painting, RAL 2000
- Cable reels 50 m
- Nozzle brush movement

## Optional

- Compressor (55 kW, 8'900 L/min, 7,5 bar max)
- Manual cable reels 80 m
- ATEX cofiguration
- Kit additives tank 1000 l with 15 m of pipes
- Second radio control
- Low flammable oil
- Fire suppression system on Diesel engine
- Rear view camera

## MOBILE CONCRETE SPRAYER

Shotcrete Boom	CST
Pumping Unit	PAS 206
Driven mode	Diesel
Shotcreting	Electric
Chassis	2 axles 4WD

## Pumping Unit Technical Data

Model		PAS 206
Theoretical output (Min ÷ Max)	<i>m³/h</i>	3 ÷ 20
Max. pressure on concrete	<i>bar</i>	65
Max. number of cycles per minute	<i>n°</i>	18
Concrete cylinders (diam. x stroke)	<i>mm</i>	200X600
Hopper capacity	<i>L</i>	220
Hopper filling height	<i>mm</i>	1260
Absobed power (electric)	<i>kW</i>	45
Power supply		400V / 50Hz 440V / 60Hz

## Boom Technical Data

Model		CST
Boom vertical rotation angle		±120°
1st section working angle (related to vertical position)		-20° +75°
2nd section working angle (related to 1st section)		+180°
Telescopic stroke	<i>m</i>	2,4
Longitudinal nozzle rotation		360°
Transversal nozzle rotation		±90°

## Dosing System Technical Data

Model		Uniflux H1
Theoretical output (Min ÷ Max)	<i>l/min</i>	1 ÷ 21
Max pressure	<i>bar</i>	13
Accelerator tanks	<i>l</i>	280

## Truck Chassis Technical Data

Model		Shottruck 1
Installed power	<i>kW@rpm</i>	72@2300 (3A) 55@2300 (3B)
Turning circle	<i>m</i>	3,2
Wheelbase	<i>m</i>	3,785
Coupling angle		21°
Outlet angle		23°
Truck tyres		15x24
Net Weight	<i>Kg</i>	8500
Net Weight with air compressor	<i>Kg</i>	9500

Technical data and characteristics subject to modifications without notice